



5462 LOUIE LANE
Reno, NV 89511
www.calramic.com
PH: 775-851-3580 FAX: 775-851-3582

AN106 09/08

Application Note

PARTIAL DISCHARGE TESTING AND LONG TERM RELIABILITY

OVERVIEW

High reliability life critical systems require enhanced reliability high voltage multilayer ceramic capacitors, thereby necessitating improvements in materials, design, process control, and in-process screening procedures. Given that energy stored in a capacitor is proportional to the square of the operating voltage, these capacitors can become their own source of destructive energy if internal defects are present. Consequently critical high reliability systems mandate even greater restrictions be placed on capacitors to be defect free.

This paper expands on the concept that partial discharge (PD) is a technique ideally suited to detecting critical internal defects within high voltage capacitors.

PARTIAL DISCHARGE THEORY REVIEW

Current conduction in a defective capacitor can be attributed to surface contamination, internal current conduction paths, or corona discharge across internal voids or cracks. Parts with internal defects like voids, cracks, or delaminations may not be detected using IR testing, voltage proof testing like DWV, or standard 96 hour burn-in. These parts will however exhibit increased partial discharge or corona and can be detected using partial discharge testing.

The two primary phenomena most often associated with dielectric material breakdown are partial discharge or corona, and avalanche breakdown. Partial discharge occurs when the gas found within a void ionizes causing a breakdown or a conduction of current across the void. Avalanche breakdown, on the other hand, occurs within the solid itself and is characterized by an uncontrolled growth of free electrons generated through electron collisions within the solid above a threshold of avalanche voltage. In high voltage capacitors, this dielectric avalanche or breakdown voltage is much higher than the ionization voltage associated with gasses contained in voids. This effectively allows for coronal discharge detection in advance of avalanche breakdown. Three conditions are needed for corona to occur. First a gas must be present, as corona discharge can only occur within a gas and not

in liquid or solid medium. Secondly, corona requires a high voltage and low current environment. As such, there has to be high impedance in series with the discharge for corona to occur and typically the dielectric material between the electrodes and gas in a void provides this high impedance. Third and less importantly, there must be some type of electrode material present. Metal electrodes however are not necessary for coronal to occur as dielectric material may act in this capacity.

Once these conditions are met, electrons within the void will propagate away from the negative conductor in the direction of corona growth. Above a threshold voltage additional free electrons are generated through molecular collisions similar to avalanche breakdown in solids. This threshold voltage required for gas ionization is defined by Paschen's Law and is a function of gas composition and pressure. Applied voltages have to be in excess of approximately 320 Volts (Paschen's Minimum) for corona to occur in air at standard temperature and pressure. This corona inception voltage (CIV) is independent of electrode spacing or void size and when gas pressures drop the corona inception voltage also drops. AC partial discharge testing should therefore utilize voltages greater than the corona inception voltage to insure ionization independent of gas type or pressure in the void.

Assuming that the electric field in the void effectively goes to zero when breakdown occurs, an additional E field stress is placed on the dielectric in series with the flaw or void. Prior to breakdown, the voltage or E field gradient is proportional to the dielectric constant or permittivity of the dielectric material between the electrodes. Ceramic dielectric materials have significantly higher permittivity values than air, so most of the applied voltage appears across the defective or void prior to breakdown. Figure 1 depicts a void, resulting series capacitors and relative voltages across those capacitors.

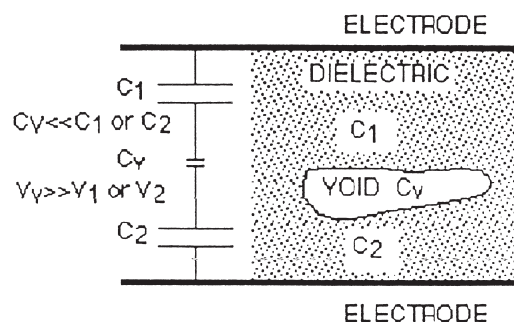

Figure 1. Void Between Electrodes

Once ionization has occurred at a defect, the void acts like a floating plate between electrodes, increasing E field gradients across the remaining dielectric material and temporarily increasing localized capacitance. Figure 2 is the equivalent circuit of parallel capacitors replacing internal electrodes. The equivalent capacitor at a void site will have a higher value due to the “floating electrode” at an ionized defect. Remember capacitance is proportional to the physical distance between electrodes, which has been reduced by the void ionizing. $Cap=kA/t$ where t is the dielectric thickness.

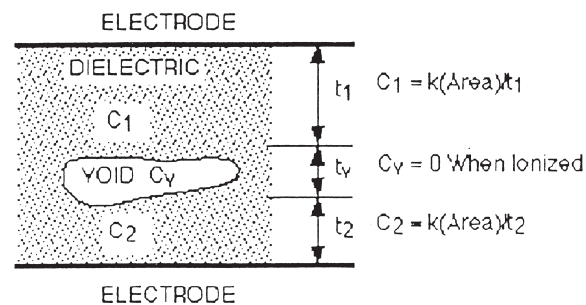

Figure 2. Equivalent Capacitors at Ionized Void

Void or defect size has an impact on the amplitudes of the discharge because two different conduction mechanisms are involved. Very small or near microscopic voids or dielectric pores will have low discharge intensities near the corona inception voltage, typically near 10 pC (pico Coulombs) at the CIV. These discharges are caused by the Townsend-type mechanism, and are characterized by a small spark or a single avalanche event with a short duration (< 10 nS), and are not detrimental to part reliability. At voltages greater than the CIV, PD values are higher because $Q=CV$ where Q is charge, C is the void capacitance and V is the applied voltage. Larger dielectric voids, cracks, or delaminations will have discharge amplitudes greater than 122 pC, when applied voltage is greater than the CIV. These discharges are of the streamer type, where a column or stream of charge occurs instead of a single spark during ionization. Consequently, there is a higher peak charge transfer for a longer duration (> 100 nS) in this type of failure. Streamer discharges will exhibit avalanche like characteristics when tested under PD conditions or high impedance circuits. Typically, a PD test threshold of 100 pC or less, industry standard maximum test voltages of .42 times the DC rating, and exposure times of less than 5 seconds, are needed to detect harmful defects in the capacitor where the streamer conduction mechanism is present.