



# Product Specification

Product Name:	Magnetic Buzzer
Part Number:	EMX-6B03L
Version:	1.02
Date:	2019-11-4
Note:	

East is an ISO 9001 , IATF16949 and ISO 14001 Certified Company

## Revision History

Rev.	Description	Author/Date	Checked By	Approver
1.02	Quality management system revised	汤礼东 2019-11-4	吕文斌	王建成
1.01	Quality Certificate Symbol revised	刘进 2015-6-25	汤礼东	王建成
1.0	Released	汤礼东 2012-3-10	陈启旺	王建成

## 1. Part Number EMX-6B03L

## 2. Dimension Drawing (Unit: mm)

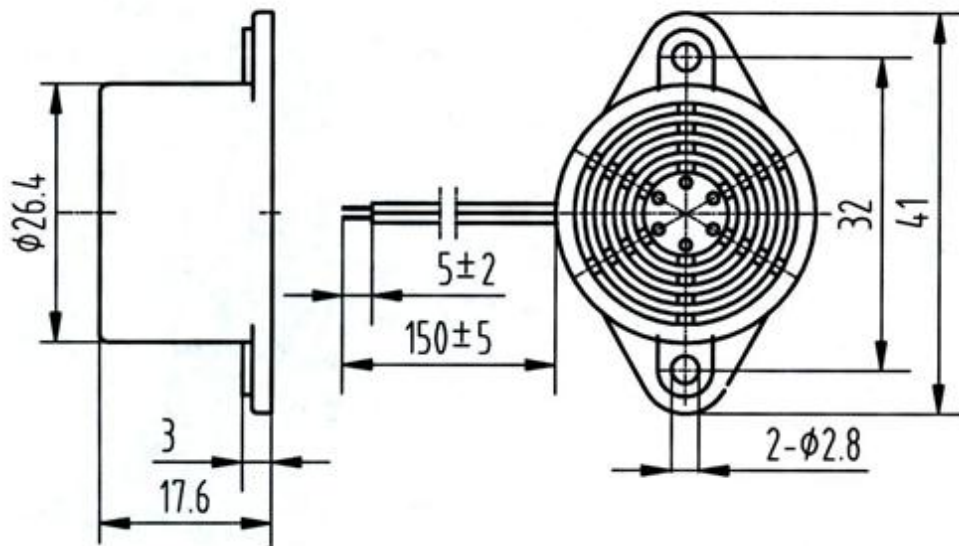

## 3. Specification

No.	Item	Specification
3-1	Min. Sound Pressure Level	73dB/3V <sub>DC</sub> /100cm
3-2	Rated Voltage	3V <sub>DC</sub>
3-3	Operating Voltage	2~5V <sub>DC</sub>
3-4	Max. Consumption	20mA/3V <sub>DC</sub>
3-5	Resonant Frequency	400±100Hz
3-6	Operating Temperature	-40~+70°C
3-7	Storage Temperature	-40~+80°C
3-8	Weight	17g

### NOTES:

Test should be made under the conditions of room temperature (20±10°C), normal humidity (60±20%) and normal atmospheric pressure. In this case, however, that the judgment is questionable, the test conditions are to be changed to room temperature 20±2°C, relative humidity 60~70% and normal atmospheric pressure

#### 4. Typical Frequency Response Curve

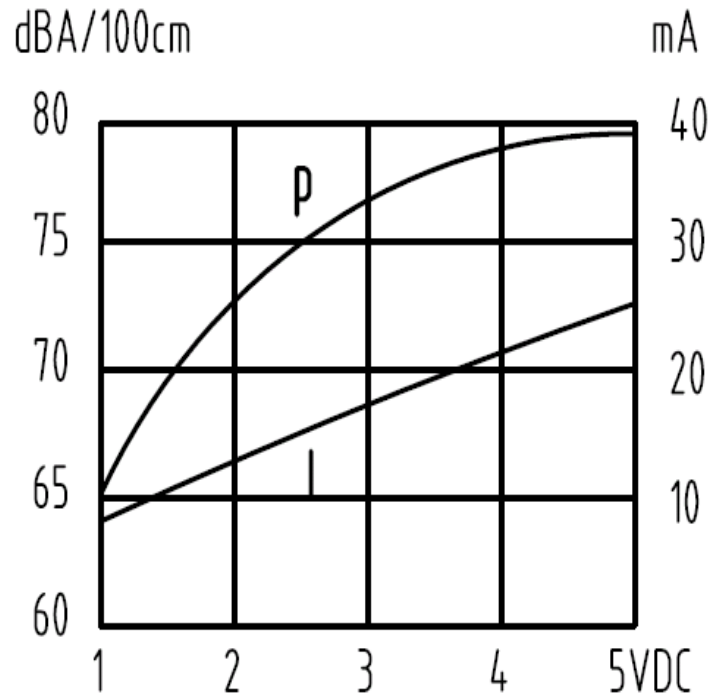

**Note:**Distance 100 cm

#### 5. Reliability Test

No.	Item	Method of Test	Tolerance after Testing
5-1	Operating Temperature	-40~+70°C	Sound pressure level initial value $\pm 10$ dB  Max. consumption value $\pm 20\%$  Oscillating frequency value $\pm 20\%$
5-2	Storage in high temperature	Storage in +80°C test box 96 hours then exposed to the room temperature for 2 hours	
5-3	Storage in low temperature	Storage in -40°C test box 96 hours then exposed to the room temperature for 2 hours	
5-4	Life test in the room temperature	Operate the product continuously 5 seconds on 5 seconds off 300 hours at rated voltage	
5-5	Temperature / humidity cycle test	Storage in +40°C, 93 $\pm$ 3%RH test box 96 hours then exposed to the room temperature for 2 hours	
5-6	Temperature (high and low) cycle test	Conduct the test for 5 cycles without applying power then expose to the room temperature for 2 hours.(See Figure 5-6)	
5-7	Vibration test	Conduct the test for the directions of X Y and Z for 0.5 hour each (total 1.5 hours). To-and Fri sweep time(from 10 to 55Hz and then 55 to 10) under single amplitude of 0.75mm is 3 minute, then expose to the room temperature for 2 hours	

5-8 Drop test

Drop a product naturally from the height of 700mm onto the surface of 100mm thick wooden board. Two directions: upper and side of the product are to be applied for this drop test once respectively

Figure 5-6

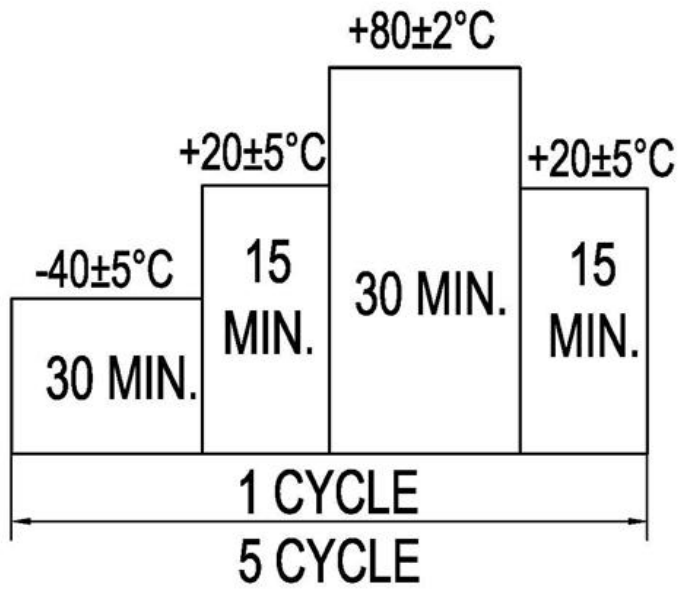

## 6. Electrical Testing Method

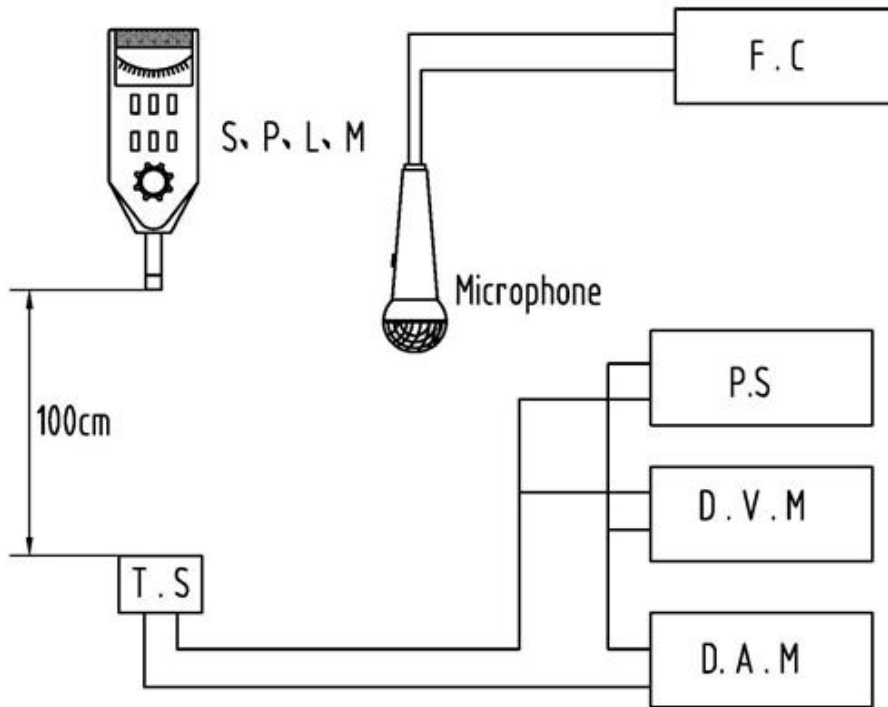

S.P.L.M	Sound Pressure Level Meter
T.S	Testing Sample
F.C	Frequency Counter
P.S	Power Supply
D.V.M	DC Voltage Meter
D.A.M	DC Ampere Meter

## 7. Packing Information

**Packing: 500 pcs per export carton**

**Carton Size: 39.5× 20× 21.5 cm**

**G. Weight: 10.0 kgs N. Weight: 8.5 kgs**