



Product Specification

| | |
|---------------|-----------------|
| Product Name: | Magnetic Buzzer |
| Part Number: | EMX-6B48L |
| Version: | 1.02 |
| Date: | 2019-11-4 |
| Note: | |

East is an ISO 9001 , IATF16949 and ISO 14001 Certified Company

Revision History

| Rev. | Description | Author/Date | Checked By | Approver |
|------|------------------------------------|------------------|------------|----------|
| 1.02 | Quality management system revised | 汤礼东 2019-11-4 | 吕文斌 | 王建成 |
| 1.01 | Quality Certificate Symbol revised | 刘进 2015-6-25 | 汤礼东 | 王建成 |
| 1.0 | Released | 汤礼东 2012-3-10 | 陈启旺 | 王建成 |

1. Part Number EMX-6B48L

2. Dimension Drawing (Unit: mm)

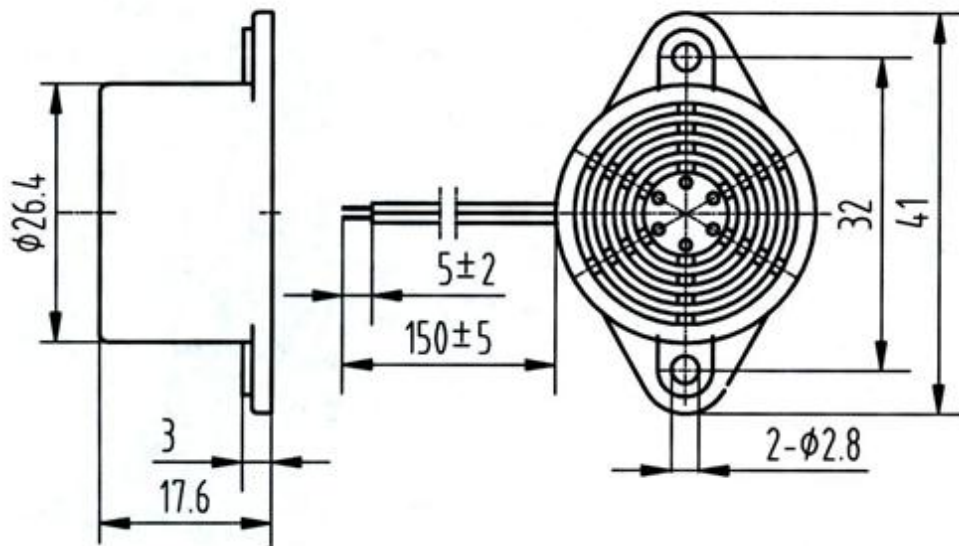

3. Specification

| No. | Item | Specification |
|-----|---------------------------|-------------------------------|
| 3-1 | Min. Sound Pressure Level | 75dB/48V _{DC} /100cm |
| 3-2 | Rated Voltage | 48V _{DC} |
| 3-3 | Operating Voltage | 36~55V _{DC} |
| 3-4 | Max. Consumption | 40mA/48V _{DC} |
| 3-5 | Oscillating Frequency | 400±100Hz |
| 3-6 | Operating Temperature | -40~+70°C |
| 3-7 | Storage Temperature | -40~+80°C |
| 3-8 | Weight | 17g |

NOTES:

Test should be made under the conditions of room temperature (20±10°C), normal humidity (60±20%) and normal atmospheric pressure. In this case, however, that the judgment is questionable, the test conditions are to be changed to room temperature 20±2°C, relative humidity 60~70% and normal atmospheric pressure

4. Typical Frequency Response Curve

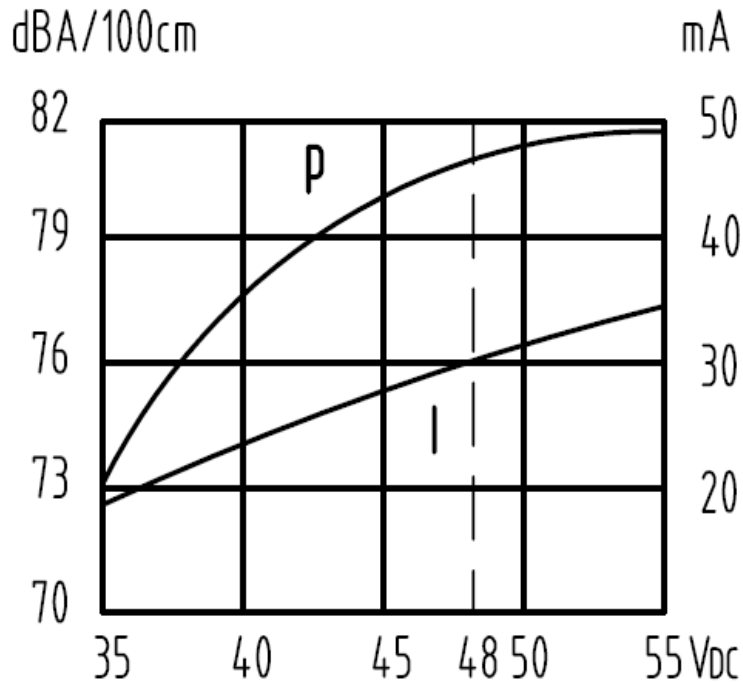

Note:Distance 100 cm

5. Reliability Test

| No. | Item | Method of Test | Tolerance after Testing |
|-----|---------------------------------------|--|---|
| 5-1 | Operating Temperature | -40~+70°C | Sound pressure level initial value ± 10 dB Max. consumption value $\pm 20\%$ Oscillating frequency value $\pm 20\%$ |
| 5-2 | Storage in high temperature | Storage in +80°C test box 96 hours then exposed to the room temperature for 2 hours | |
| 5-3 | Storage in low temperature | Storage in -40°C test box 96 hours then exposed to the room temperature for 2 hours | |
| 5-4 | Life test in the room temperature | Operate the product continuously 5 seconds on 5 seconds off 300 hours at rated voltage | |
| 5-5 | Temperature / humidity cycle test | Storage in +40°C, 93 \pm 3%RH test box 96 hours then exposed to the room temperature for 2 hours | |
| 5-6 | Temperature (high and low) cycle test | Conduct the test for 5 cycles without applying power then expose to the room temperature for 2 hours.(See Figure 5-6) | |
| 5-7 | Vibration test | Conduct the test for the directions of X Y and Z for 0.5 hour each (total 1.5 hours). To-and Fri sweep time(from 10 to 55Hz and then 55 to 10) under single amplitude of 0.75mm is 3 minute, then expose to the room temperature for 2 hours | |

| | | | |
|-----|-----------|--|--|
| 5-8 | Drop test | Drop a product naturally from the height of 700mm onto the surface of 100mm thick wooden board. Two directions: upper and side of the product are to be applied for this drop test once respectively | |
|-----|-----------|--|--|

Figure 5-6

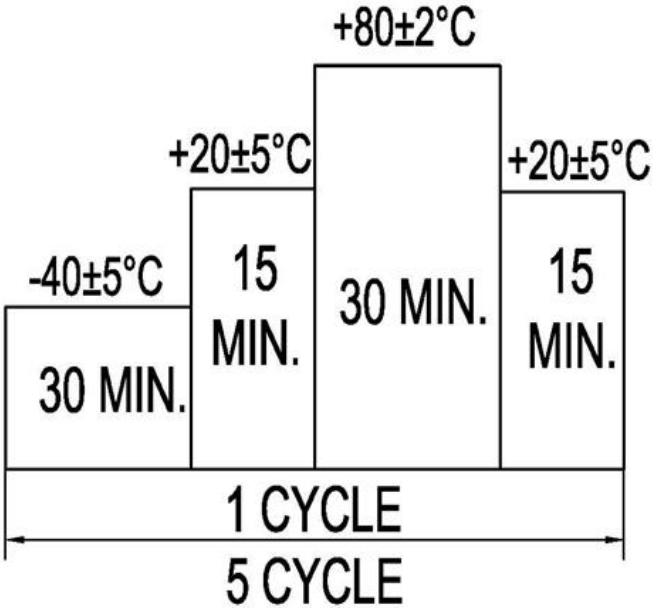

6. Electrical Testing Method

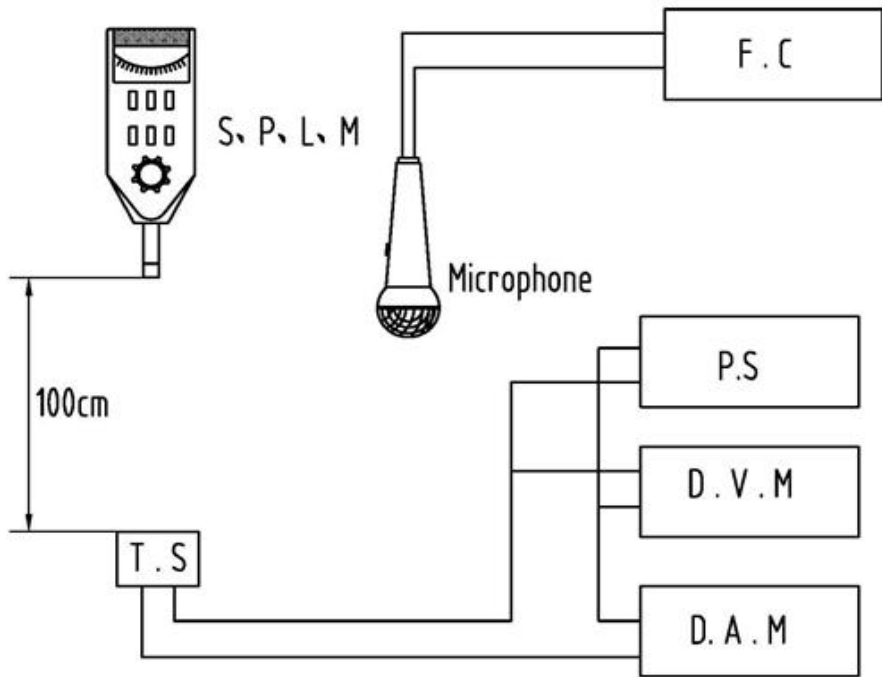

| | |
|---------|----------------------------|
| S.P.L.M | Sound Pressure Level Meter |
| T.S | Testing Sample |
| F.C | Frequency Counter |
| P.S | Power Supply |
| D.V.M | DC Voltage Meter |
| D.A.M | DC Ampere Meter |

7. Packing Information

Packing: 500 pcs per export carton

Carton Size: 39.5× 20×21.5 cm

G. Weight: 10 kgs N. Weight: 8.5 kgs