

Front VIEW

Back VIEW

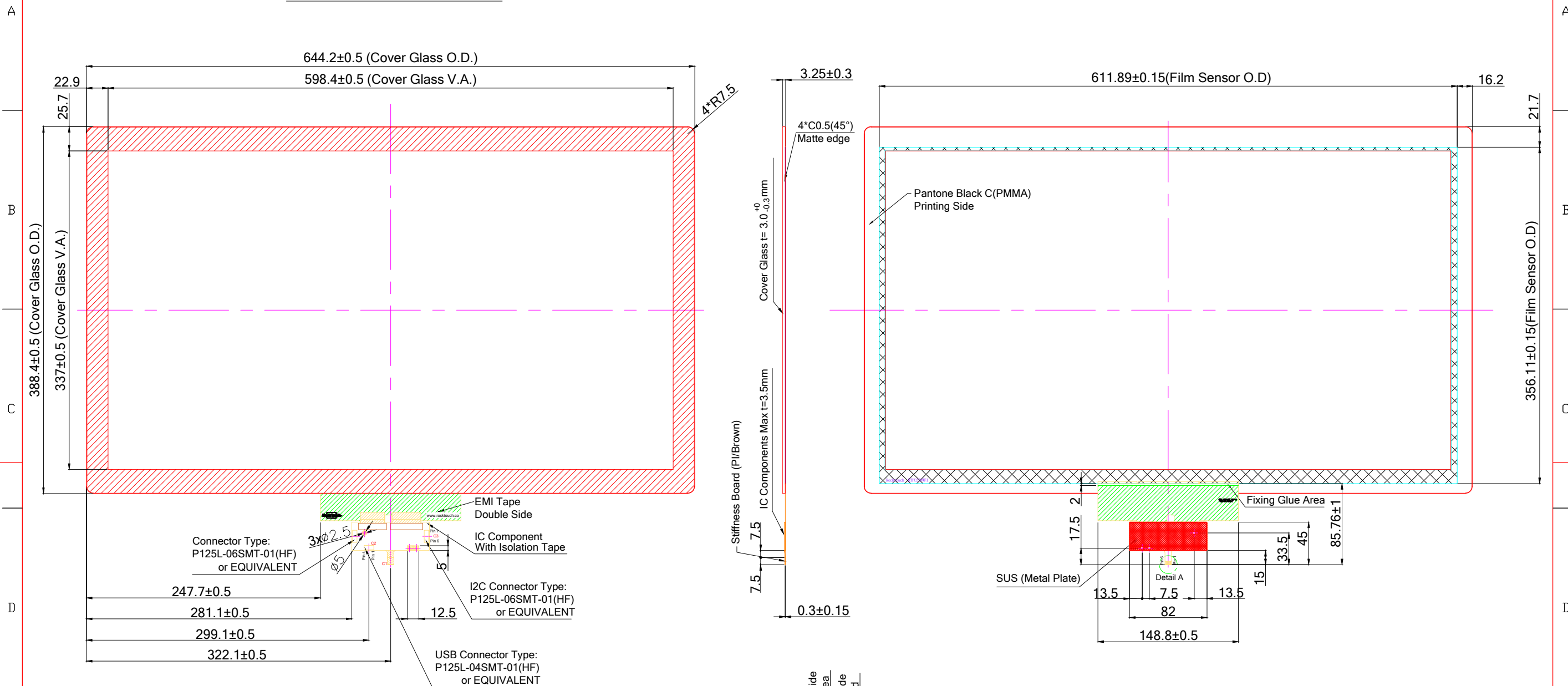

- Spec:
- 1. General O.D. Tolerance : ±0.5
 - 2. Border Type : Matte
 - 3. Glass Type : Semi-Tempered
 - 4. Surface treatment : None
 - 5. Background Printing : PMMA Pantone Black C
 - 6. Logo Printing : None
 - 7. Transmittance Level : >85%
 - 8. Important Notes :

Note:

- A. Distance between LCD and Touch need to have minimum 1 mm otherwise thinner dimension can cause noise problem between LCD and touch screen
- B. If customer put a front conductive bezel all around we need to have minimum thickness of 2mm, if the thickness is lower can cause interference
- C. Refer to the integration guide to avoid any integration noise issue
- D. Before mass production customer needs to ask custom firmware for his final machine

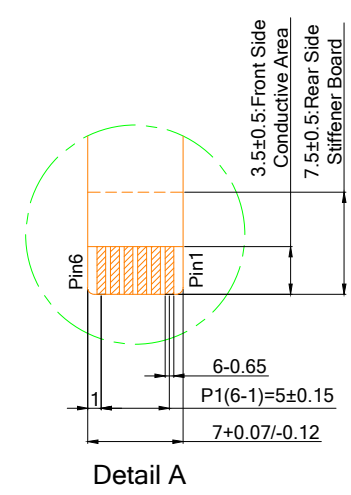

C1:USB Interface		C2: Pin Define for USB 4 pin		C3: Pin Define for I2C 6 pin	
Pin 01	GND	Pin 01	GND	Pin 01	GND
Pin 02	D-	Pin 02	D-	Pin 02	SDA
Pin 03	D+	Pin 03	D+	Pin 03	SCL
Pin 04	VDD(5V)	Pin 04	VDD	Pin 04	VDD(5V)
Pin 05	NC			Pin 05	INT
Pin 06	RST			Pin 06	RST

Customer Approval		Part Number		RTPC270WF1-R1-30BP1-C	
Date	Rev	Date	Person	Description	
Company					
Name					
Signature		Date	Design By	Date	Check By
		20180801	Jeff	20180828	Kevin
				Date	Approved By
				20180906	Jeff

