



Product Specification

Product Name:	Speaker
Part Number:	SEM-36R4.7-8N0.8R (8Ω 0.8W)
Version:	Rev. 1.01
Date:	2020-11-24
Note:	

East is an ISO 9001 , IATF16949 and ISO 14001 Certified Company

Revision History

Rev.	Description	Author/Date	Checked By	Approver
1.00	Released	Lv Wenbin Jul. 09. 2020	Gao Rong	Wang Jiancheng
1.01	Modify the spring	Lv Wenbin Nov. 24. 2020	Gao Rong	Wang Jiancheng

1. Part Number : SEM-36R4.7-8N0.8R

2. Dimension Drawing: (Unit: mm)

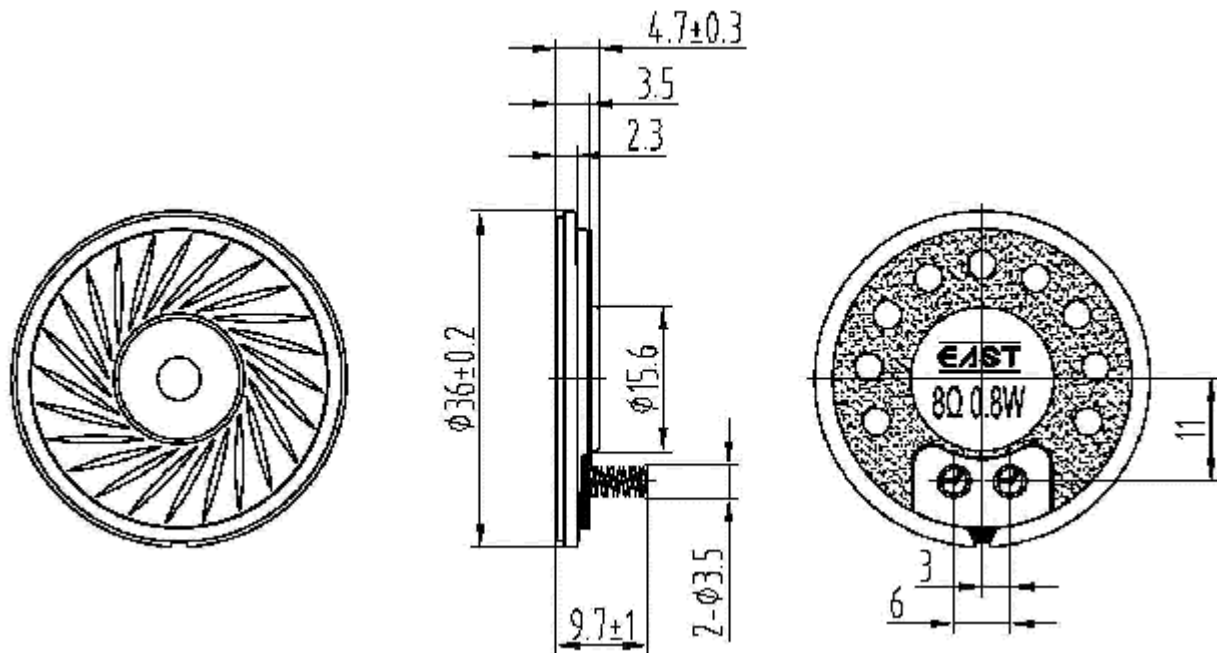

3. Specification :

No.	Items	Specification
3-1	Rated impedance	$8\Omega \pm 15\%$ at 1.5kHz
3-2	Resonant frequency (f_0)	$600\text{Hz} \pm 20\%$ 1.0 V
3-3	SPL normal power input	$98\text{dB} \pm 3$ 0.1M / 0.8W (800,1000,1200,1500Hz average) 2.53V
3-4	Frequency range	$f_0 \sim 20\text{kHz}$ SPL-10dB 2.53V
3-5	Distortion	$< 5\%$ at 1kHz 2.53V
3-6	Normal power	0.8 W @ Rated noise power operating continuously for 100 hours 2.53V
3-7	Maximum power	1.0W @ Stimulant program signal for 1 min. on & 2 min. off, cycling for 10 times 2.83V
3-8	Appearance normal	@ A.T. 15~35°C, H.M. 25~75%, B.P. 86~106kPa
3-9	Buzzes & rattles no appearance	@ 0.3m with sine wave from 300Hz to 5 kHz input/rated noise power 2.53 V
3-10	Diaphragm material	Mylar
3-11	Weight	9.6g

NOTES :

1. Test in anechoic room and use the IEC standard baffle which size at : 1350 mm (W) X 1650 mm (H)
2. Test should be made under the conditions of room temperature ($20 \pm 10^\circ\text{C}$), relative humidity ($60 \pm 20\%$) and normal atmospheric pressure. In this case, however, that the judgment is questionable, the test conditions are to be changed to room temperature $20 \pm 2^\circ\text{C}$, relative humidity 60~70% and normal atmospheric pressure.

4. Typical Frequency Response Curve:

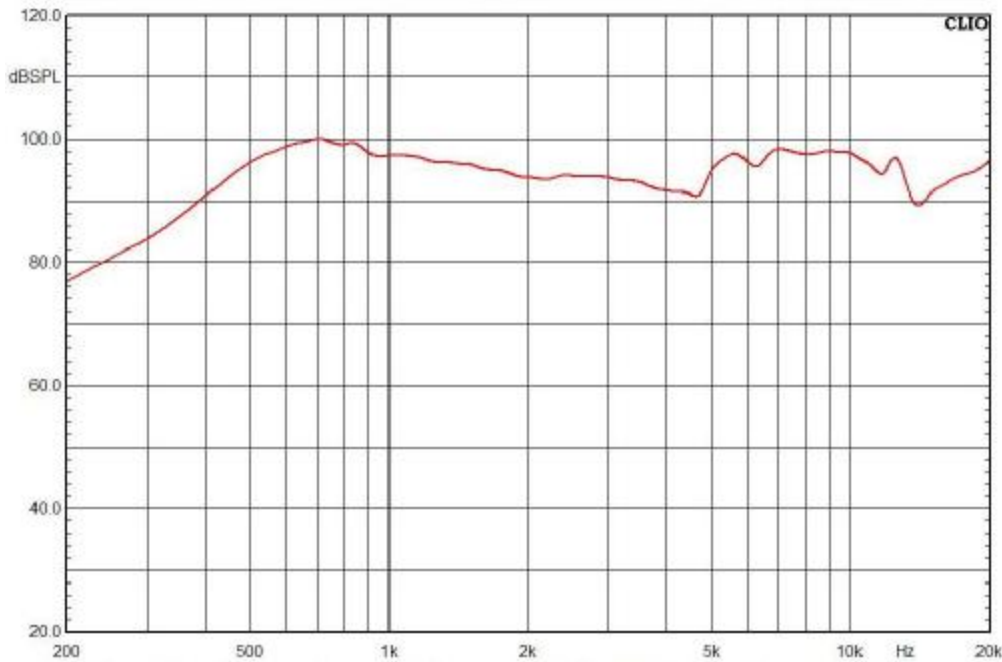

5. Reliability Test:

No.	Item	Method of Test	Tolerance after Testing
5-1	Operating temperature	-25 °C ~ +70°C	
5-2	High-temperature loading & storage	@ ¼ rated noise power /80± 2 °C operating for 16 hours then depositing for 2 hours at constant temperature, completing testing within 1 hour after withdrawing.	Meet requirements of Appearance, Buzzes & rattles after test
5-3	Low-temperature loading & storage	@ ¼ rated noise power/-10 ± 3 °C operating for 1 hours, depositing @ -30± 3 °C for 2 hours, then resuming at normal atmosphere conditions (GB/T 9396-1996 4.2) for 4 hours.	Meet requirements of Appearance, Buzzes & rattles, solderability after test
5-4	Static humidity/temperature	@ A.T. 40 ± 2 °C, H.M.93±2 % depositing for 48 hours, then resuming @ normal atmosphere conditions (GB/T9396-1996 4.2) for 24 hours.	Meet Requirements of Appearance, Buzzes & rattles, insulation resistance, bearing voltage after test
5-5	Temperature (high and low) cycle test	Storage in -30 °C ± 5 °C for 2hours, in 20 °C ± 5 °C for 2 hours, in 80 °C ± 5 °C for 2 hours then back in 20 °C ± 5 °C 2 hours, as one cycle. 12 cycle in total.	Appearance: no obviously damage Tone: no obviously noise
5-6	Drop test	Drop a product naturally from the height of 1000 mm onto the surface of 100 mm thick wooden board. Two directions: upper and side of the product are to be applied for this drop test once respectively.	
5-7	Life test in the room temperature	Input the signal with the valid frequency range on the speaker in continuously for 100 hours, the room temperature should control in 15 °C to 35 °C.	
5-8	Vibration test	Conduct the test for the directions of X Y and Z for 0.5 hour each (total 1.5 hours). To-and Fri sweep time(from 10 to 55 Hz and then 55 to 10) under single amplitude of 0.75 mm is 3 minute, then expose to the room temperature for 2 hours.	SPL ±3dB F0 ±20% ACR ±15%

NOTE: The frame is allowed to deform after drop test.

6. Electrical Testing Method:

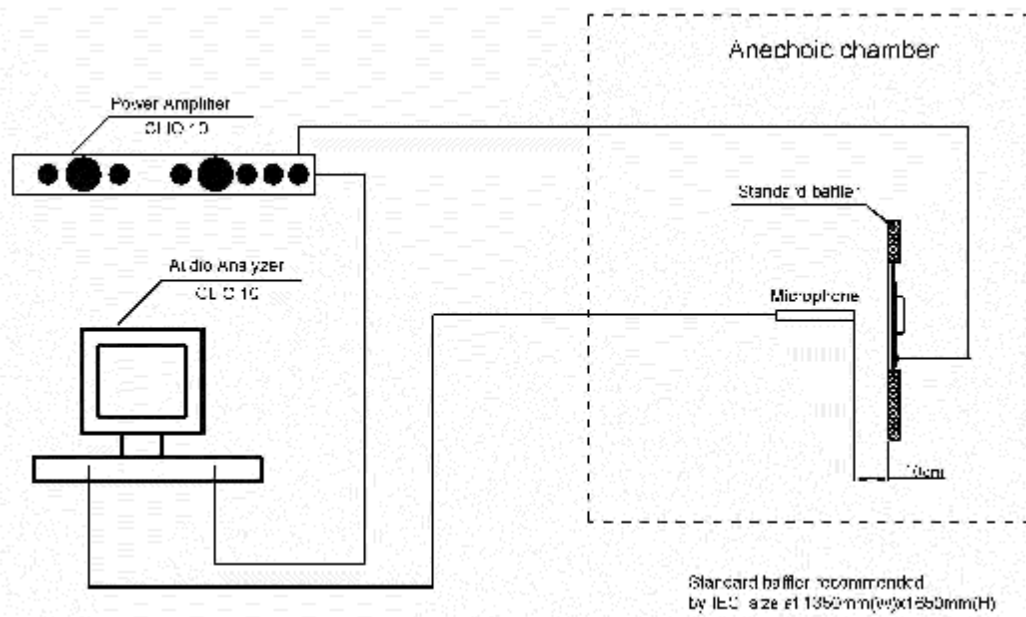

Anechoic chamber

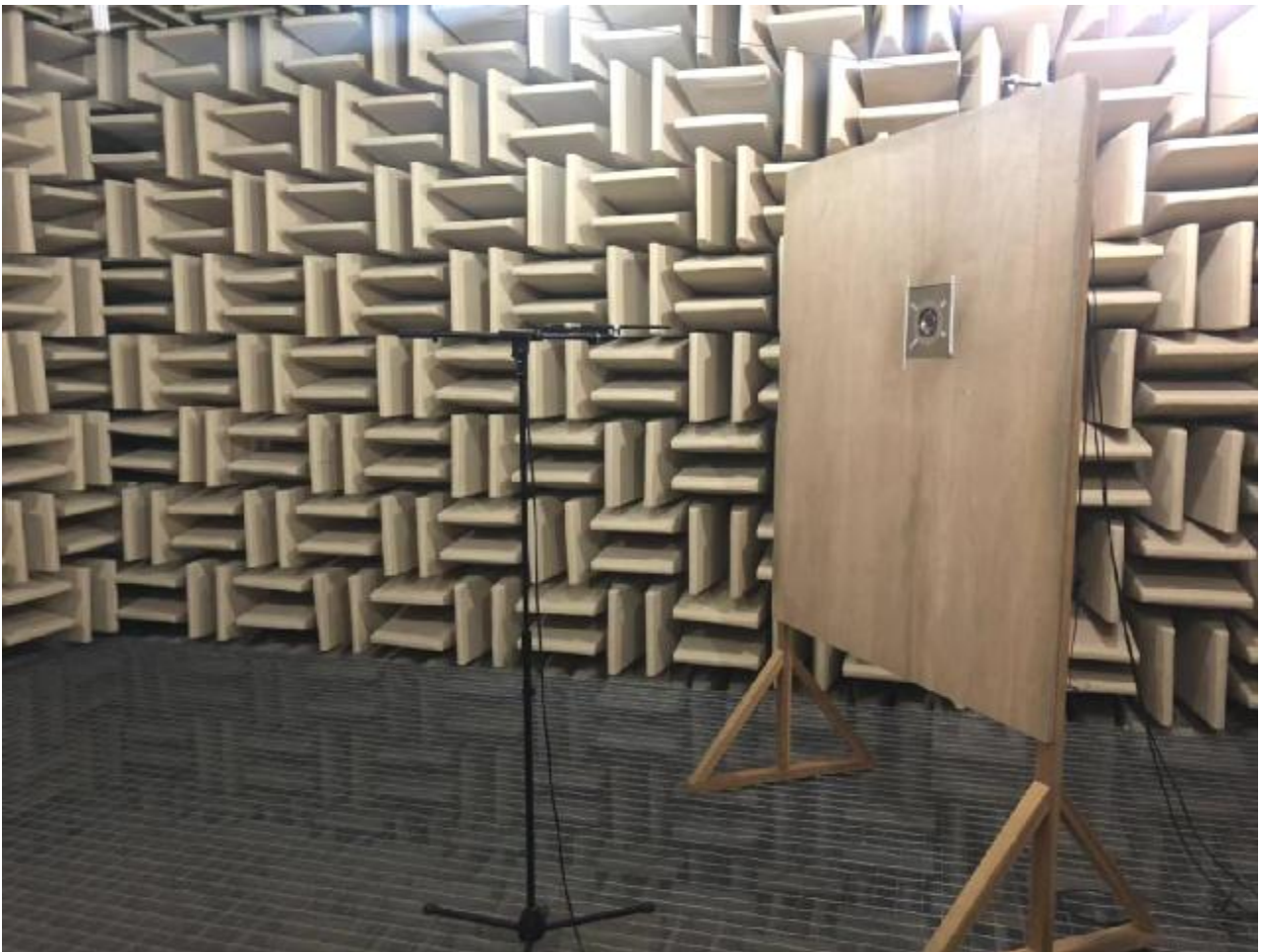

7. Packing Information:



30PCS / EPE/Cardboard tray

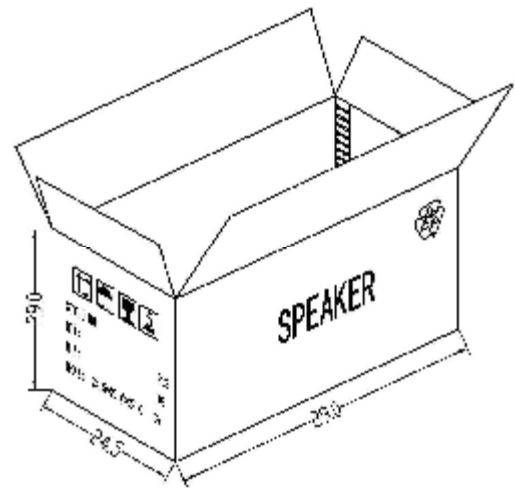

Shipping Carton

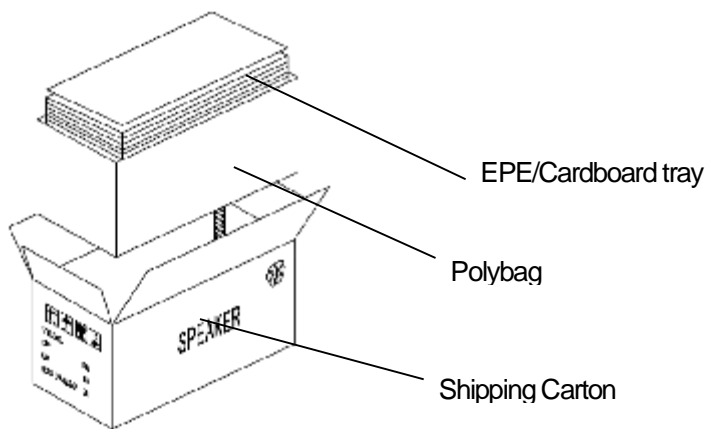

Packing information:

1. Packing: 480 pcs per export carton
2. Carton Size: 29×24.5×29 cm
3. N.W:4.6 kg G.W:6.6 kg