



Product Specification

Product Name:	SMD External -Driven Piezo Transducer
Part Number:	SFM-1241
Version:	1.03
Date:	2019-10-8
Note:	

East is an ISO 9001 , IATF16949 and ISO 14001 Certified Company

Revision History

Rev.	Description	Author/Date	Checked By	Approver
1.03	Quality management system revised	汤礼东 2019-10-8	吕文斌	王建成
1.02	change the paper reel to plastic reel	刘进 2015-5-30	汤礼东	王建成
1.01	Quality Certificate Symbol revised	刘宁 2015-2-4	汤礼东	王建成

1. Part Number SFM-1241

2. Dimension Drawing (Unit: mm)

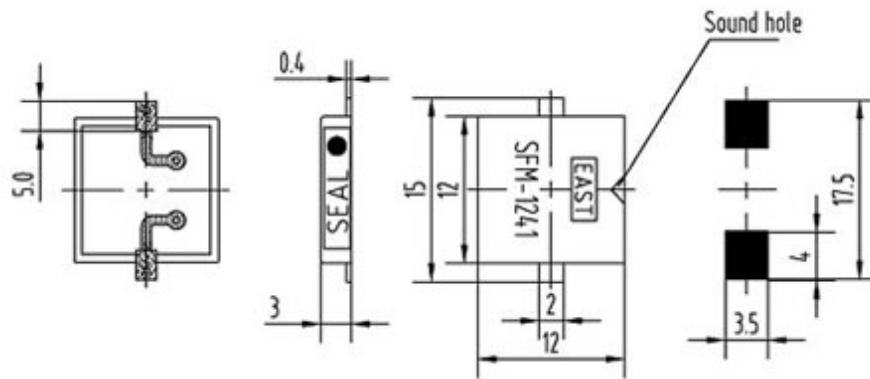

Recommended Version SMD Foot Pattern

Solder paste thickness is not below 0.2mm
The seal will be removed after reflow soldering

3. Specification

No.	Item	Specification
3-1	Min. Sound Pressure Level	75dB/4.1kHz/5Vp-p square wave /10cm
3-2	Allowed Input Voltage	20Vp-p
3-3	Capacitance	16±30% nF (At 1000Hz)
3-4	Max. Consumption	3mA/4.1kHz/5Vp-p square wave
3-5	Resonant Frequency	4.1± 0.5kHz
3-6	Operating Temperature	-20~+105°C
3-7	Case Material /Color	PPS/Black
3-8	Weight	0.7g
3-9	Pin Strength	More than 10N

NOTES:

Test should be made under the conditions of room temperature (20±10°C), normal humidity (60±20%) and normal atmospheric pressure. In this case, however, that the judgment is questionable, the test conditions are to be changed to room temperature 20±2°C, relative humidity 60~70% and normal atmospheric pressure

4. Typical Frequency Response Curve

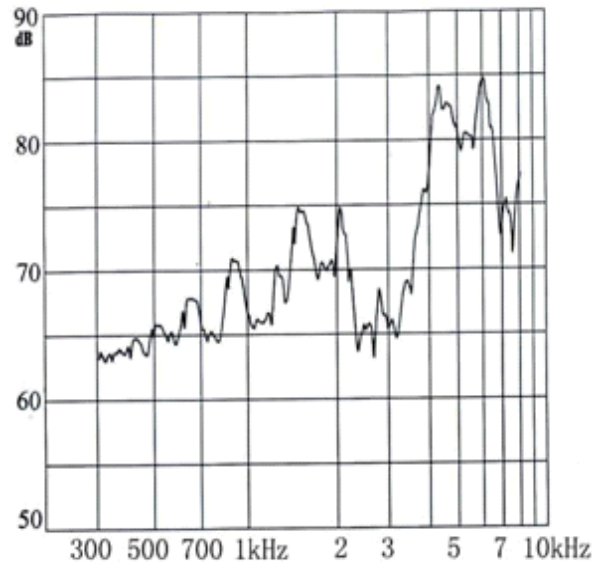

Note: Input Voltage 5Vp-p square wave
Distance 10 cm

5. Reliability Test

No.	Item	Method of Test	Tolerance after Testing
5-1	Operating Temperature	-20~+105°C	Sound pressure level initial value ± 10 dB Max. consumption value $\pm 20\%$ Capacitance value $\pm 20\%$
5-2	Storage in high temperature	Storage in +105°C test box 96 hours then exposed to the room temperature for 2 hours	
5-3	Storage in low temperature	Storage in -20°C test box 96 hours then exposed to the room temperature for 2 hours	
5-4	Life test in the room temperature	Operate the product continuously 5 seconds on 5 seconds off 300 hours at rated voltage	
5-5	Temperature / humidity cycle test	Storage in +40°C, 93 \pm 3%RH test box 96 hours then exposed to the room temperature for 2 hours	
5-6	Temperature (high and low) cycle test	Conduct the test for 5 cycles without applying power then expose to the room temperature for 2 hours.(See Figure 5-6)	
5-7	Vibration test	Conduct the test for the directions of X Y and Z for 0.5 hour each (total 1.5 hours). To-and Fri sweep time(from 10 to 55Hz and then 55 to 10) under single amplitude of 0.75mm is 3 minute, then expose to the room temperature for 2 hours	

5-8	Drop test	Drop a product naturally from the height of 700mm onto the surface of 100mm thick wooden board. Two directions: upper and side of the product are to be applied for this drop test once respectively	
5-9	Reflow soldering heat resistance	a)Pre-heating conditions shall be +140°C to 160°C for 160 to 200 seconds. (See Figure5-9) b)Heating conditions shall be within 60 seconds at +200°C min., but peak temperature shall be lower than +260°C. (See Figure 5-9)	
5-10	Test of soldering	Dip the connecting pins in soldering at 230±5°C for 3±0.5 seconds	Solder shall be attached around over 95% of the dipped portion

NOTE: The pins are allowed to deform after drop test.

Figure 5-6

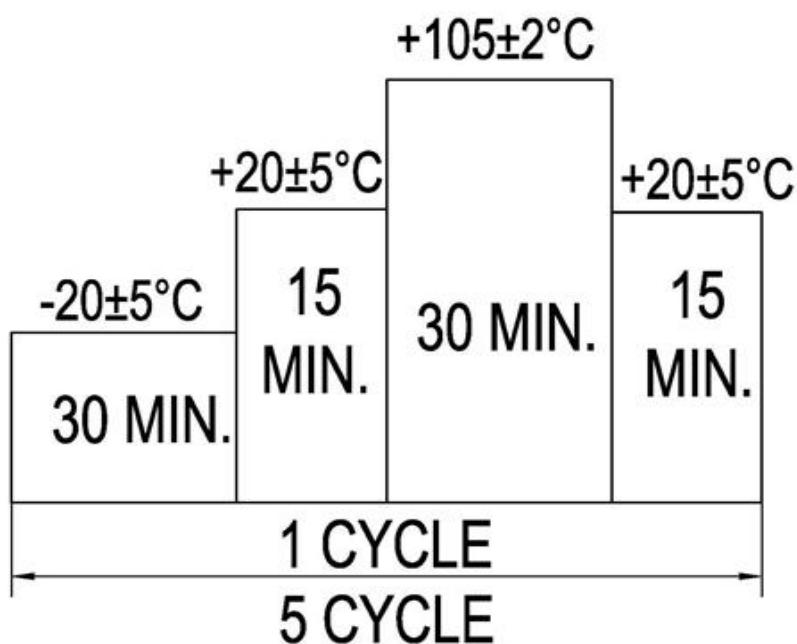
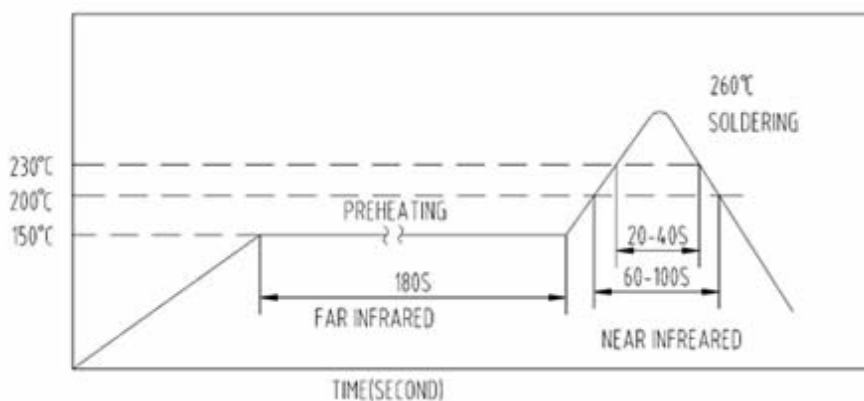
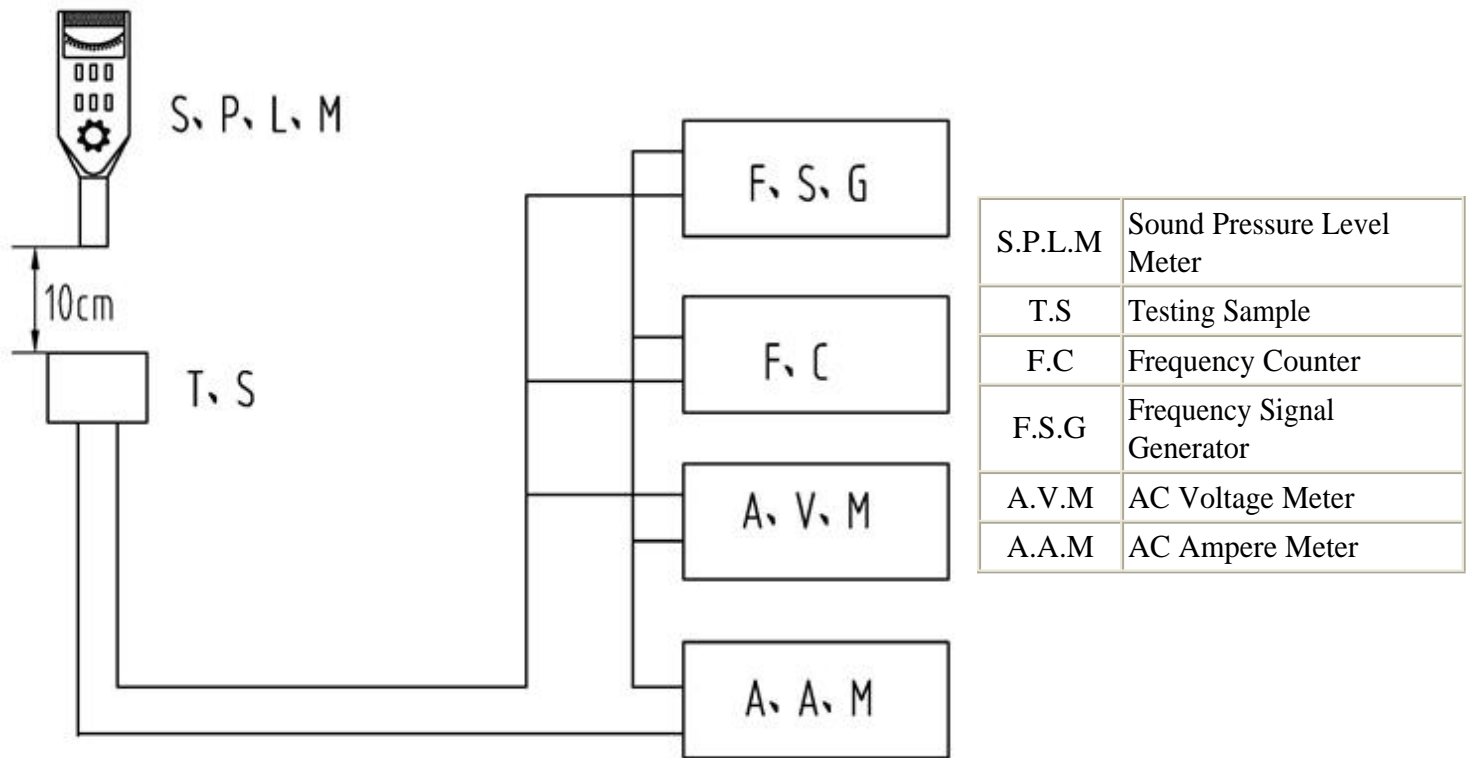

Figure 5-9



6. Electrical Testing Method



7. Packing Information

No.	Item	Description
7-1	Tape type information	a)The design for such tape packing was executed under standard IEC - 286-3 b)The material of the tape is polystyrene in black color. Detailed dimensions are as below: (See Figure7-1)
7-2	Dimensions of the rolling plate	a) The material of the rolling plate is plastic. b) The dimensions of the rolling plate are as below(See Figure7-2)
7-3	Packing dimensions and quantity	a) The rolling plate is put into a 340X335X35mm inner packing box and is packed with 1000pcs of transducer per plate. b) The dimension of the outer carton is 400X 350X 350mm containing 10 inner boxes with a total quantity of 10000 pcs of transducer. c) The total gross weight per carton is 13.6Kgs, while net weight is 7.0Kgs.

Figure 7-1

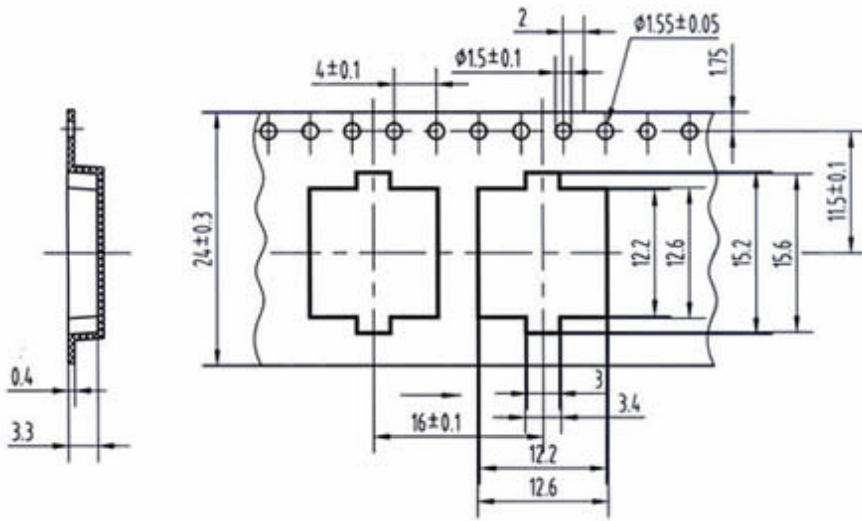

Figure 7-2

