



Product Specification

Product Name:	Self-Driven Pizeo Transducer
Part Number:	TFM-28
Version:	1.02
Date:	2015-2-12
Note:	

Company passed ISO 9001 / ISO TS16949 / ISO 14001 Certifications

Revision History

Rev.	Description	Author/Date	Checked By	Approver
1.02	Quality Certificate Symbol revised	刘宁 2015-2-12	汤礼东	王建成
1.01	Testing circuit changed	张春雷 2013-3-21	汤礼东	王建成
1.0	Released	汤礼东 2012-5-8	陈启旺	王建成

1. Part Number TFM-28

2. Dimension Drawing (Unit: mm)

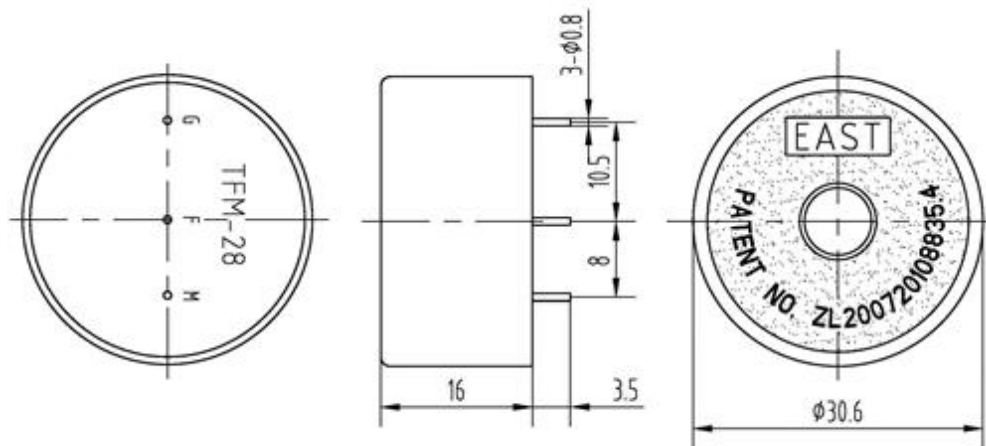

3. Specification

No.	Item	Specification
3-1	Min. Sound Pressure Level	95dB/9V _{DC} /30cm
	Min. Sound Pressure Level	85dB/9V _{DC} /300cm
3-2	Rated Voltage	9V _{DC}
3-3	Operating Voltage	6~14V _{DC}
3-4	Max. Consumption	30mA/9V _{DC}
3-5	Oscillating Frequency	3.4±0.5 KHz
3-6	Operating Temperature	-20~+70°C
3-7	Case Material/Color	PC/Black
3-8	Weight	6g
3-9	Pin Strength	More than 10N

NOTES:

Test should be made under the conditions of room temperature (20±10°C), normal humidity (60±20%) and normal atmospheric pressure. In this case, however, that the judgment is questionable, the test conditions are to be changed to room temperature 20±2°C, relative humidity 60~70% and normal atmospheric pressure

4. Typical Frequency Response Curve

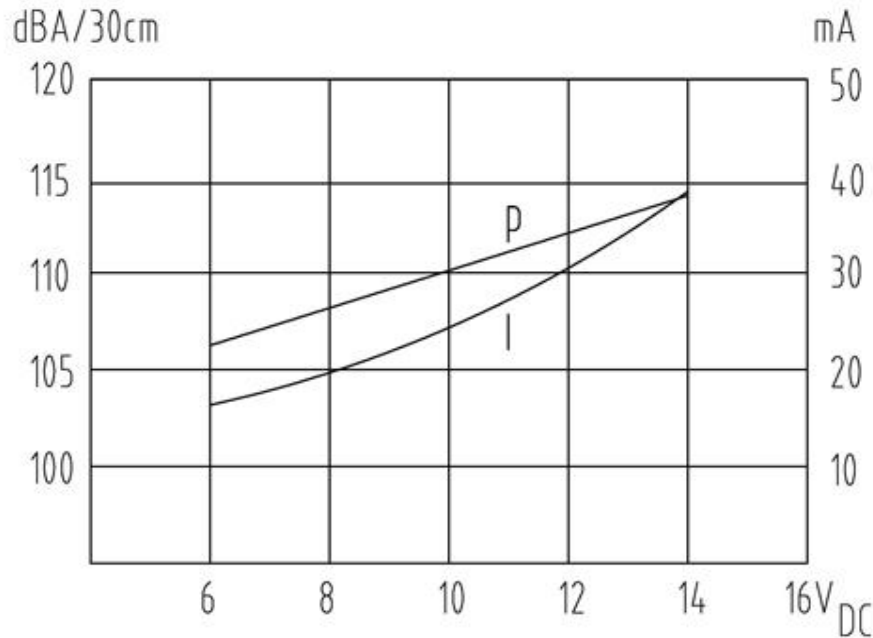

Note:Distance 30 cm

5. Reliability Test

No.	Item	Method of Test	Tolerance after Testing
5-1	Operating Temperature	-20~+70°C	Sound pressure level initial value ±10dB Max. consumption value ±20% Oscillating frequency value±20%
5-2	Storage in high temperature	Storage in +70°C test box 96 hours then exposed to the room temperature for 2 hours	
5-3	Storage in low temperature	Storage in -20°C test box 96 hours then exposed to the room temperature for 2 hours	
5-4	Life test in the room temperature	Operate the product continuously 5 seconds on 5 seconds off 300 hours at rated voltage	
5-5	Temperature / humidity cycle test	Storage in +40°C, 93±3%RH test box 96 hours then exposed to the room temperature for 2 hours	
5-6	Temperature (high and low) cycle test	Conduct the test for 5 cycles without applying power then expose to the room temperature for 2 hours.(See Figure 5-6)	
5-7	Vibration test	Conduct the test for the directions of X Y and Z for 0.5 hour each (total 1.5 hours). To-and Fri sweep time(from 10 to 55Hz and then 55 to 10) under single amplitude of 0.75mm is 3 minute, then expose to the room temperature for 2 hours	

5-8	Drop test	Drop a product naturally from the height of 700mm onto the surface of 100mm thick wooden board. Two directions: upper and side of the product are to be applied for this drop test once respectively	
5-9	Soldering heat resistance test	Dip the connecting pins in soldering at $260\pm 5^{\circ}\text{C}$ for 10 ± 1 seconds	
5-10	Test of soldering	Dip the connecting pins in soldering at $230\pm 5^{\circ}\text{C}$ for 3 ± 0.5 seconds	Solder shall be attached around over 95% of the dipped portion

NOTE: The pins are allowed to deform after drop test.

Figure 5-6

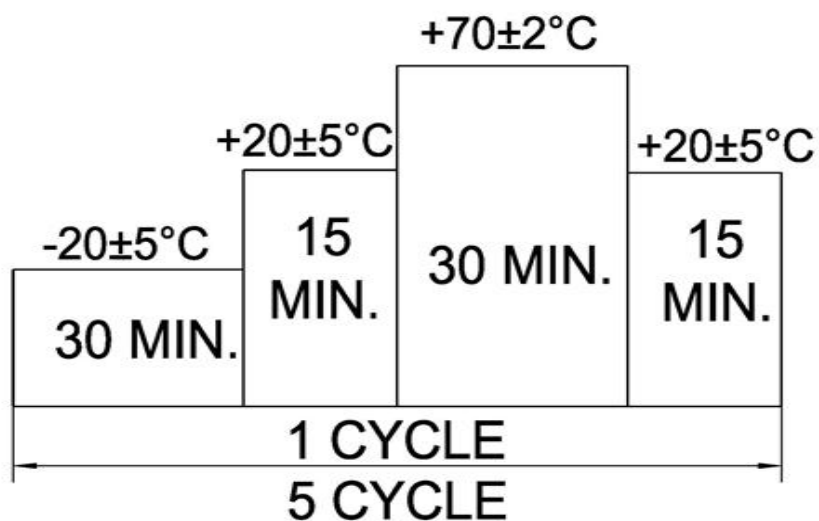

6. Electrical Testing Method

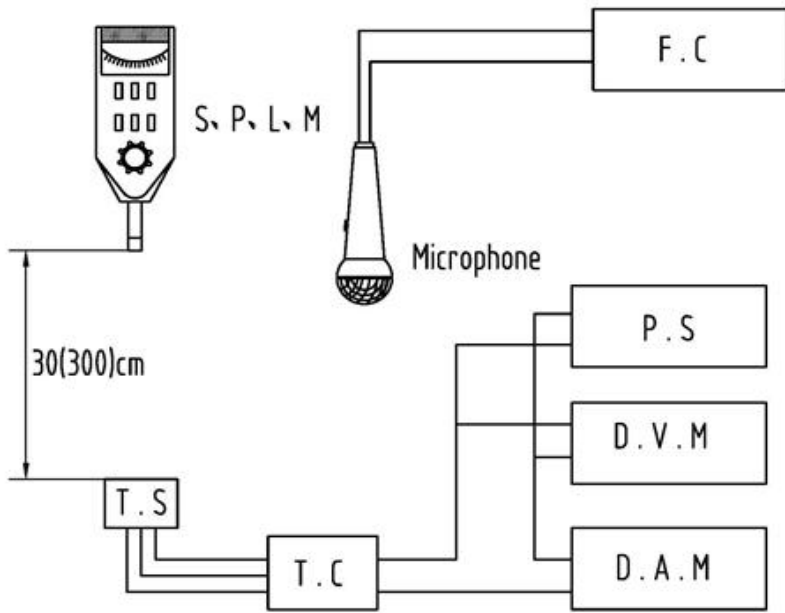

S.P.L.M	Sound Pressure Level Meter
T.S	Testing Sample
T.C	Testing Circuit
F.C	Frequency Counter
P.S	Power Supply
D.A.M	DC Ampere Meter
D.V.M	DC Voltage Meter

Testing Circuit:

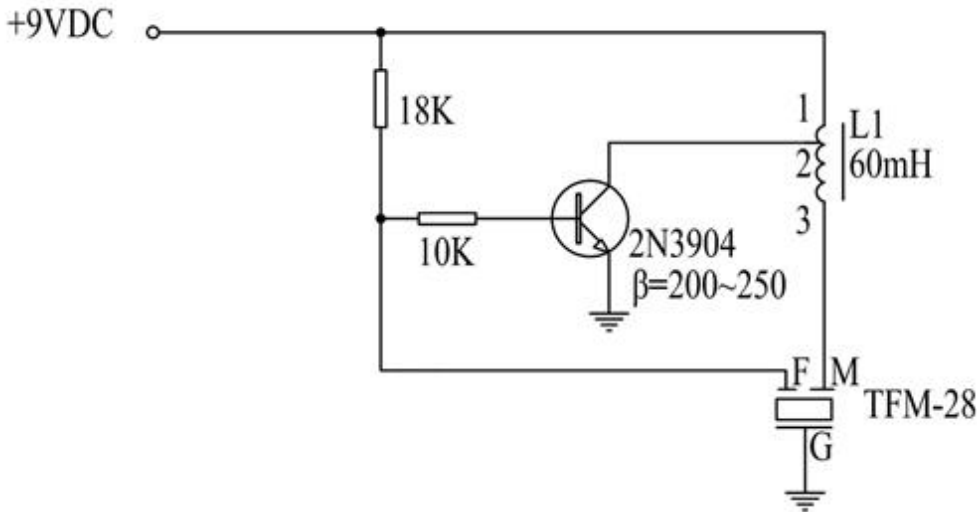

7. Packing Information

Packing: 960 pcs per export carton

Carton Size: 47× 30.5× 36 cm

G. Weight: 7.5 kgs N. Weight: 5.8 kgs