



Product Specification

Product Name:	External-Driven Piezo Transducer
Part Number:	TFM-83L3520
Version:	1.01
Date:	2015-5-11
Note:	

Company passed ISO 9001 / ISO TS16949 / ISO 14001 Certifications

Revision History

Rev.	Description	Author/Date	Checked By	Approver
1.01	Quality Certificate Symbol revised	刘进 2015-5-11	汤礼东	王建成
1.0	Released	汤礼东 2011-8-11	张春雷	王建成

1. Part Number TFM-83L3520

2. Dimension Drawing (Unit: mm)

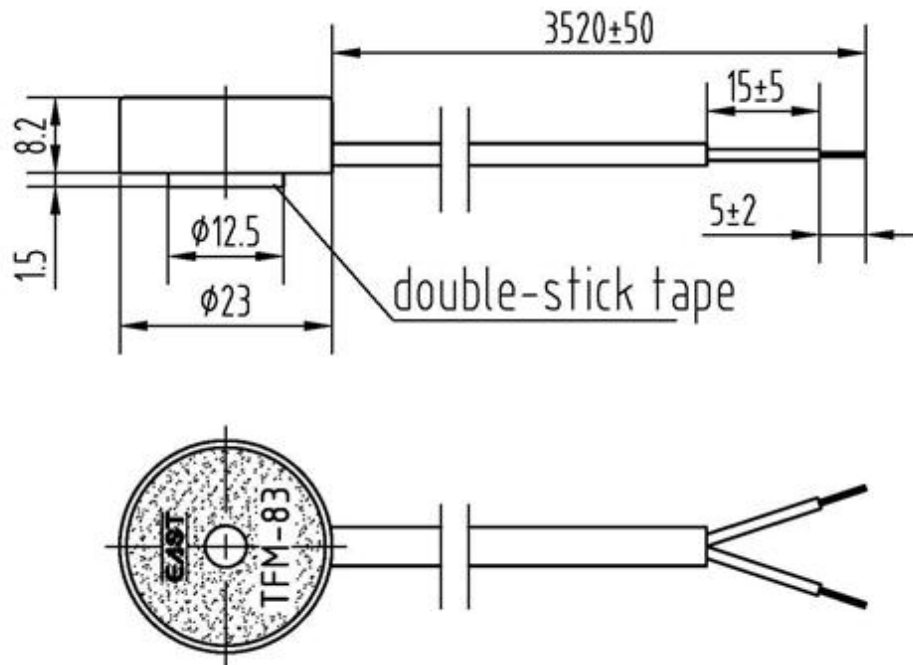

3. Specification

No.	Item	Specification
3-1	Min. Sound Pressure Level	80dB/4.0kHz/3Vp-p square wave /10cm
	Min. Sound Pressure Level	70dB/1.33kHz/3Vp-p square wave /10cm
3-2	Allowed Input Voltage	40Vp-p
3-3	Capacitance	13±30% nF (At 1000Hz)
3-4	Max. Consumption	3.5mA/4.0kHz/3Vp-p square wave
3-5	Resonant Frequency	4.0± 0.5kHz
3-6	Operating Temperature	-20~+70°C
3-7	Case Material /Color	PC/Black
3-8	Weight	70g
3-9	Wire Standard	2C×24AWG(UL1095)

NOTES:

Test should be made under the conditions of room temperature (20±10°C), normal humidity (60±20%) and normal atmospheric pressure. In this case, however, that the judgment is questionable, the test conditions are to be changed to room temperature 20±2°C, relative humidity 60~70% and normal atmospheric pressure

4. Typical Frequency Response Curve

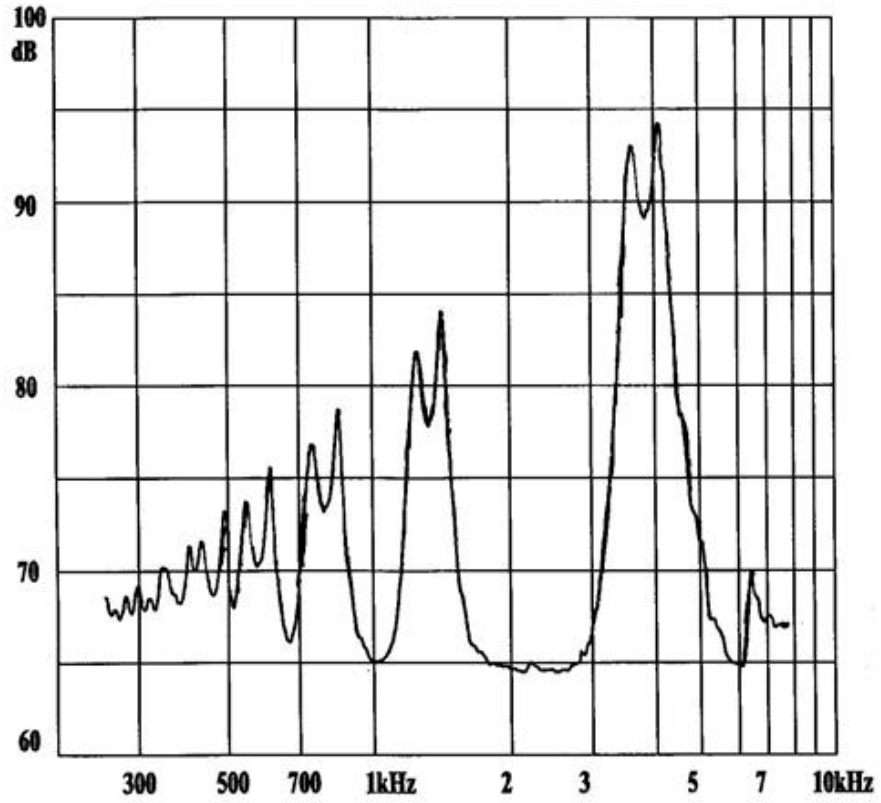

Note: Input Voltage 3Vp-p square wave
Distance 10 cm

5. Reliability Test

No.	Item	Method of Test	Tolerance after Testing
5-1	Operating Temperature	-20~+70°C	Sound pressure level initial value $\pm 10\text{dB}$ Max. consumption value $\pm 20\%$ Capacitance value $\pm 20\%$
5-2	Storage in high temperature	Storage in +70°C test box 96 hours then exposed to the room temperature for 2 hours	
5-3	Storage in low temperature	Storage in -20°C test box 96 hours then exposed to the room temperature for 2 hours	
5-4	Life test in the room temperature	Operate the product continuously 5 seconds on 5 seconds off 300 hours at rated voltage	
5-5	Temperature / humidity cycle test	Storage in +40°C, 93 \pm 3%RH test box 96 hours then exposed to the room temperature for 2 hours	
5-6	Temperature (high and low) cycle test	Conduct the test for 5 cycles without applying power then expose to the room temperature for 2 hours.(See Figure 5-6)	
5-7	Vibration test	Conduct the test for the directions of X Y and Z for 0.5 hour each (total 1.5 hours). To-and Fri sweep time(from 10 to 55Hz and then 55 to 10) under single amplitude of 0.75mm is 3 minute, then expose to the room temperature for 2 hours	
5-8	Drop test	Drop a product naturally from the height of 700mm onto the surface of 100mm thick wooden board. Two directions: upper and side of the product are to be applied for this drop test once respectively	

Figure 5-6

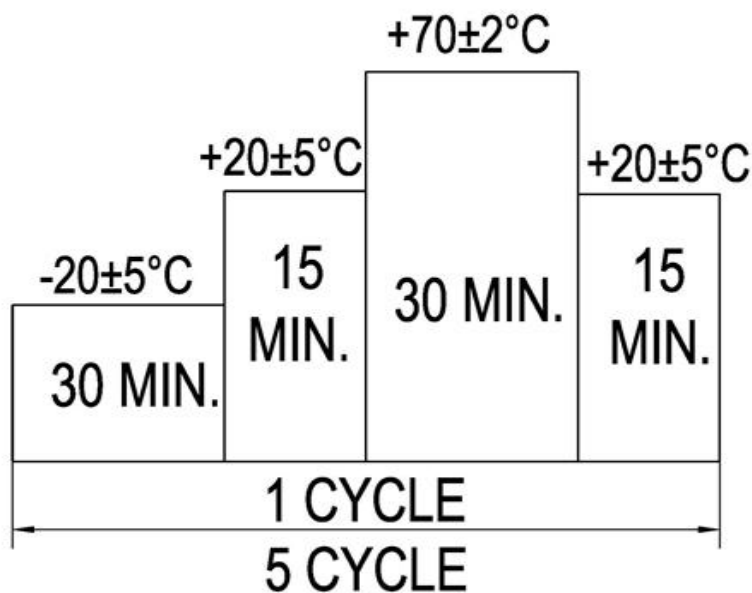

6. Electrical Testing Method

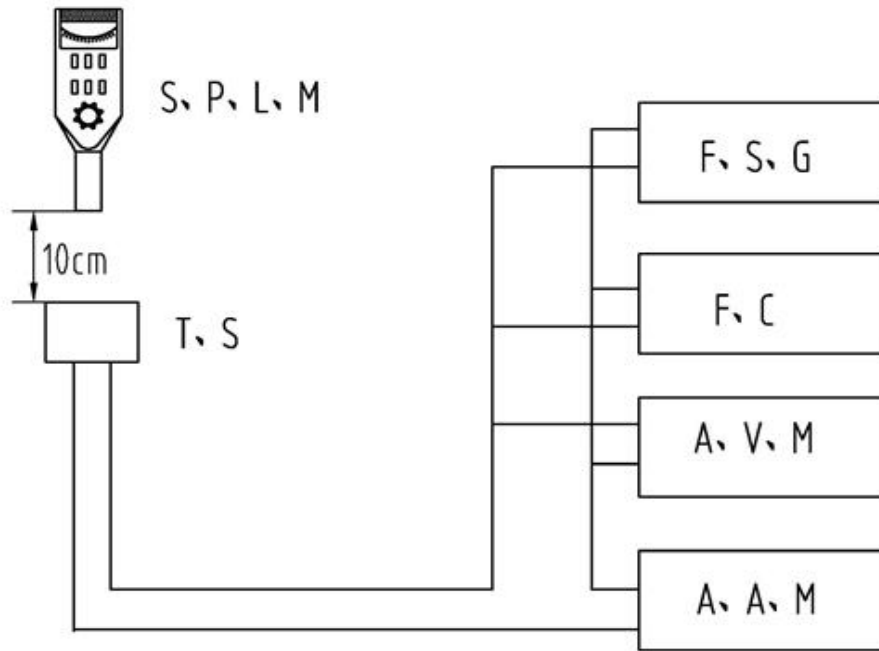

S.P.L.M	Sound Pressure Level Meter
T.S	Testing Sample
F.C	Frequency Counter
F.S.G	Frequency Signal Generator
A.V.M	AC Voltage Meter
A.A.M	AC Ampere Meter

7. Packing Information

Packing: 160 pcs per export carton

Carton Size: 47× 30.5× 25 cm

G. Weight: 13.1 kgs **N. Weight:** 9.7 kgs