



# Product Specification

Product Name:	High-Output Piezo Alarm Transducer
Part Number:	W-07
Version:	1.02
Date:	2019-10-16
Note:	

East is an ISO 9001 , IATF16949 and ISO 14001 Certified Company

## Revision History

Rev.	Description	Author/Date	Checked By	Approver
1.02	Quality management system revised	汤礼东 2019-10-16	吕文斌	王建成
1.01	Quality Certificate Symbol revised	刘宁 2015-2-12	汤礼东	王建成
1.0	Released	汤礼东 2012-1-6	张春雷	王建成

## 1. Part Number W-07

## 2. Dimension Drawing (Unit: mm)

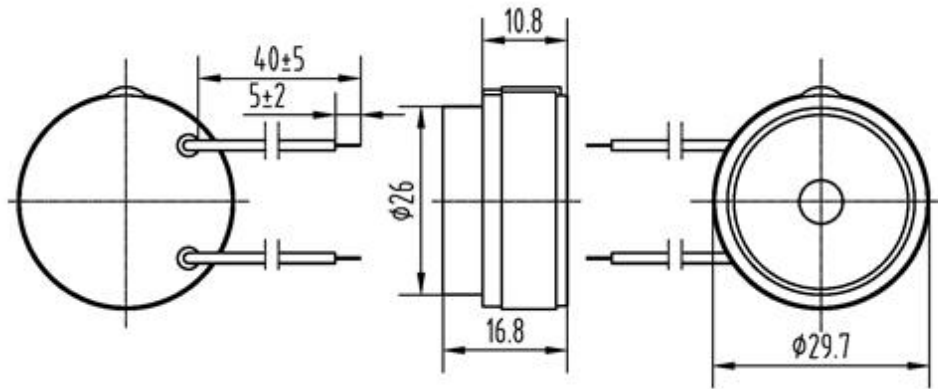

## 3. Specification

No.	Item	Specification
3-1	Min. Sound Pressure Level	100dB/9V <sub>DC</sub> /30cm
3-2	Rated Voltage	9V <sub>DC</sub>
3-3	Max. Consumption	180mA/9V <sub>DC</sub>
3-4	Capacitance	25nF $\pm$ 30%(at 120Hz)
3-5	Oscillating Frequency	3.2 $\pm$ 0.5 kHz
3-6	Tone Nature	Continuous
3-7	Operating Temperature	-20~+70°C
3-8	Case Material/Color	ABS/White
3-9	Weight	6.6g
3-10	Wire Standard	UL1095-28AWG

### NOTES:

Test should be made under the conditions of room temperature ( $20 \pm 10^\circ\text{C}$ ), normal humidity ( $60 \pm 20\%$ ) and normal atmospheric pressure. In this case, however, that the judgment is questionable, the test conditions are to be changed to room temperature  $20 \pm 2^\circ\text{C}$ , relative humidity 60~70% and normal atmospheric pressure

#### 4. Reliability Test

No.	Item	Method of Test	Tolerance after Testing
4-1	Operating Temperature	-20~+70°C	Sound pressure level initial value $\pm 10\text{dB}$ Max. consumption value $\pm 20\%$ Capacitance value $\pm 20\%$
4-2	Storage in high temperature	Storage in +70°C test box 96 hours then exposed to the room temperature for 2 hours	
4-3	Storage in low temperature	Storage in -20°C test box 96 hours then exposed to the room temperature for 2 hours	
4-4	Life test in the room temperature	Operate the product continuously 5 seconds on 5 seconds off 300 hours at rated voltage	
4-5	Temperature / humidity cycle test	Storage in +40°C, 93 $\pm$ 3%RH test box 96 hours then exposed to the room temperature for 2 hours	
4-6	Temperature (high and low) cycle test	Conduct the test for 5 cycles without applying power then expose to the room temperature for 2 hours.(See Figure 4-6)	
4-7	Vibration test	Conduct the test for the directions of X Y and Z for 0.5 hour each (total 1.5 hours). To-and Fri sweep time(from 10 to 55Hz and then 55 to 10) under single amplitude of 0.75mm is 3 minute, then expose to the room temperature for 2 hours	
4-8	Drop test	Drop a product naturally from the height of 700mm onto the surface of 100mm thick wooden board. Two directions: upper and side of the product are to be applied for this drop test once respectively	

Figure 5-6

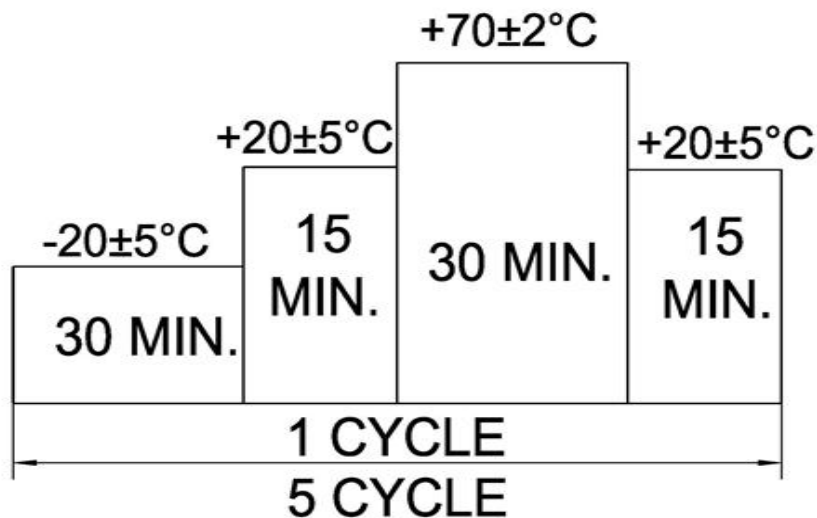

## 5. Electrical Testing Method

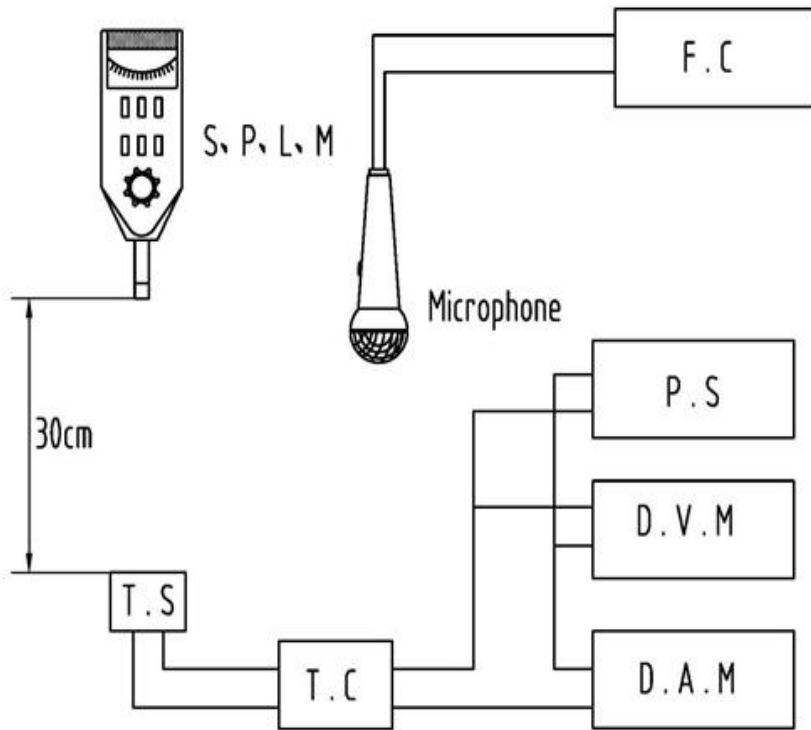

S.P.L.M	Sound Pressure Level Meter
T.S	Testing Sample
F.C	Frequency Counter
T.C	Test Circuit
P.S	Power Supply
D.V.M	DC Voltage Meter
D.A.M	DC Ampere Meter

T.C:

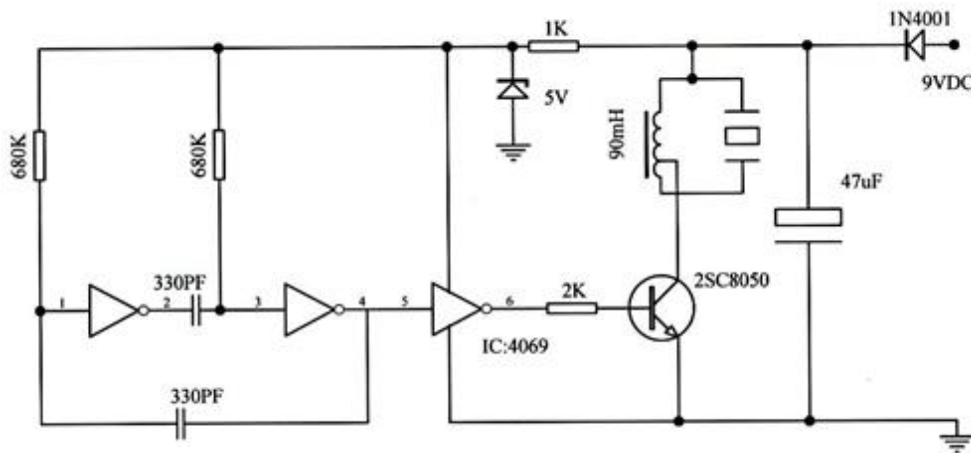

## 6. Packing Information

**Packing:** 1638 pcs per export carton

**Carton Size:** 47× 30.5× 25 cm

**G. Weight:** 13.4 kgs **N. Weight:** 10.8 kgs